

Miele

Operating and installation instructions



Wine cellar
KWL 4612 S
KWL 4812 S

To avoid the risk of accidents or damage to the appliance, it is **essential** to read these operating instructions before it is installed or used for the first time.



M.-Nr. 06 457 910

Contents

Description of the appliance	4
Caring for the environment	6
Warning and Safety instructions	7
How to save energy	10
Operation	11
Safety lock	11
The correct temperature and humidity	12
Temperature	12
Safety features	12
Setting the temperature	12
Temperature range	13
Temperature display	13
Temperature display brightness	13
Humidity level	13
Air filtering with the active charcoal filter and dynamic cooling	14
Storing wine bottles	15
Wooden shelves	15
Descriptive labels	15
Maximum capacity	15
Alarm	16
Temperature alarm	16
Door alarm	16
Switching on the alarm system	16
Switching the alarm off early	16
Defrosting	17
Cleaning and care	18
Cleaning the outer casing, the interior and accessories	18
Ventilation gaps	18
Door seal	19
Metal grille at the back of the appliance	19
Active charcoal filter	19
Problem solving guide	20
Noises	22
Service Department	23
Electrical connection	24
Electrical connection U.K.	24

Contents

Installation	25
Location	25
Climate range	25
Ventilation.	25
Installation	25
Aligning the appliance.	25
Changing the door hinging	26

Description of the appliance

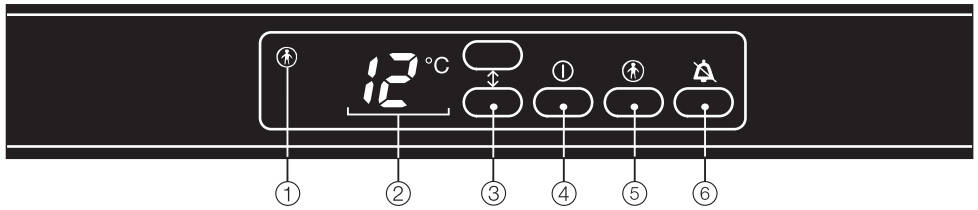

- ① Safety lock indicator light
- ② Temperature display
- ③ Controls for setting the temperature
upper button: warmer
lower button: colder
- ④ On/Off button
- ⑤ Locking button
- ⑥ Alarm off button

Description of the appliance

- ① Interior lighting
- ② Wooden shelf with décor strip for descriptive labels
- ③ Lock
- ④ Condensate channel and drain hole
- ⑤ Active charcoal filter
- ⑥ Grille

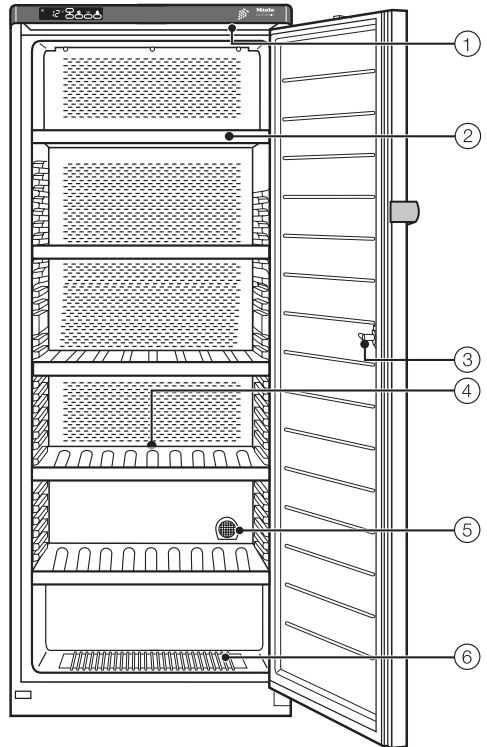

Caring for the environment

Disposal of the packing material

The transport and protective packing has been selected from materials which are environmentally friendly for disposal, and can normally be recycled.

Ensure that any plastic wrappings, bags etc. are disposed of safely and kept out of the reach of babies and young children. Danger of suffocation!

Rather than just throwing these materials away, please ensure that they are recycled.

Disposal of your old appliance

Please ensure that the appliance presents no danger to children while being stored for disposal.

It should be unplugged or disconnected from the mains electricity supply by a competent person. The plug must be rendered useless and the cable cut off directly behind the appliance to prevent misuse. See the "Warning and Safety" section of this booklet for further details.

Electrical and electronic appliances often contain materials which, if handled or disposed of incorrectly, could be potentially hazardous to human health and to the environment. They are, however, essential for the correct functioning of your appliance.

Please dispose of your old appliance at your local community waste collection / recycling centre and not with your household waste.

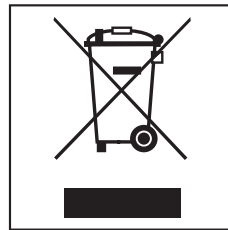

Take care not to damage the pipework at the back of it before or during transportation to an authorised collection depot.

In this way, refrigerant in the pipework and oil in the compressor will be contained, and will not leak out into the environment.

Warning and Safety instructions

This appliance complies with all relevant legal safety requirements. Improper use of the appliance can, however, present a risk of both personal injury and material damage.

To avoid the risk of accidents and damage to the appliance, read the operating instructions carefully before installation and before using for the first time. They contain important notes on the installation, safety, operation and care of the appliance.

Keep these instructions in a safe place and pass them on to any future user.

Correct usage

■ This appliance is intended for domestic use only for storing wine. Any other usage is not supported by the manufacturer and could be dangerous. The manufacturer cannot be held liable for damage caused by incorrect or improper use of the appliance.

Technical safety

■ This appliance contains the coolant Isobutane (R600a), a natural gas which is environmentally friendly. It is, however, flammable and care must be taken during transportation and setting up of the appliance that no parts of the cooling system are damaged. Leaking coolant can damage the eyes.

In the event of any damage:

- avoid open fires and anything which creates a spark,
- disconnect from the mains,
- air the room in which the appliance is located for several minutes and
- contact the Service Department for advice.

■ The more coolant there is in an appliance, the larger the room it should be installed in. In the event of a leakage, if the appliance is in a small room, there is the danger of combustible gases building up. For every 8 g of coolant at least 1 m³ of room space is required. The amount of coolant in the appliance is stated on the data plate inside the appliance.

■ Before connecting the appliance to the mains supply, make sure that the rating on the data plate corresponds to the voltage and frequency of the household supply. This data must correspond in order to avoid the risk of damage to the appliance. If in any doubt, consult a qualified electrician.

Warning and Safety instructions

■ The electrical safety of this appliance can only be guaranteed when continuity is complete between the appliance and an effective earthing system which complies with local and national safety regulations. It is most important that this basic safety requirement is present and tested regularly and where there is any doubt, the household wiring system should be inspected by a qualified electrician. The manufacturer cannot be held liable for the consequences of an inadequate earthing system (e.g. electric shock).

■ Safe operation of the appliance is only assured if it has been installed and connected in accordance with these operating and installation instructions.

■ This equipment may only be used in mobile installations such as ships, caravans, aircraft etc. if a risk assessment of the installation has been carried out by a suitably qualified engineer.

■ Installation work, maintenance and repairs may only be carried out by suitably qualified and competent persons in accordance with national and local safety regulations. Repairs and other work by unqualified persons could be dangerous and the manufacturer will not be held liable. Ensure current is not supplied to the appliance until after maintenance or repair work has been carried out.

■ The appliance is only completely isolated from the electricity supply when:

- it has been switched off at the wall socket and the plug has been withdrawn.
- the mains fuse is withdrawn, or
- the screw-out fuse is removed (in countries where this is applicable).

■ Do not connect the appliance to the mains electricity supply by an extension lead.

Extension leads do not guarantee the required safety of the appliance (e.g. danger of overheating).

Use

■ Never store explosive materials in the appliance. Thermostats switching on may produce sparks which could present a fire hazard. Flammable compounds could explode.

■ Do not use any oils or grease on the door seals, as these will cause the seals to deteriorate and become porous with time.

■ Do not block the ventilation gaps in the appliance as this would impair the efficiency of the appliance, increase the electricity consumption and could cause damage to the appliance.

Warning and Safety instructions

■ The appliance is designed for use within certain climate ranges (ambient temperatures), and should not be used outside this range. The climate range for your appliance is stated on the data plate inside the appliance. Installing it in a room with too low an ambient temperature, e.g. a garage, can lead to the appliance switching off for longer periods so that it cannot maintain the required temperature.

■ Do not use a steam-cleaning appliance to clean this appliance. Pressurised steam could reach the electrical components and cause a short circuit.

■ In countries where there are areas which may be subject to infestation by cockroaches or other vermin, pay particular attention to keeping the appliance and its surroundings in a clean condition at all times. Any damage which may be caused by cockroaches or other vermin will not be covered by the guarantee.

Disposal of your old appliance

■ Before disposing of an old appliance, first make the door latch or lock unusable.

This way you will prevent children from accidentally locking themselves in and endangering their lives.

■ Before disposing of an old appliance, unplug it and render the plug useless. Cut off the cable directly behind the appliance and at the plug to prevent misuse.

■ Be careful not to damage any part of the pipework whilst awaiting disposal, e.g. by

- puncturing the refrigerant channels in the evaporator.
- bending any pipework.
- scratching the surface coating.

Splashes of refrigerant can damage the eyes.

The manufacturer cannot be held liable for damage caused by non-compliance with these Warning and Safety instructions.

How to save energy

	normal energy consumption	increased energy consumption
Installation	In a ventilated room.	In an enclosed, unventilated room.
	Protected from direct sunlight.	In direct sunlight.
	Not situated near to a heat source (radiator, oven).	Situated near to a heat source (radiator, oven).
	Where the ambient room temperature is ideal at approx. 20°C.	Where there is a high ambient room temperature.
Temperature setting with a thermostat which is approximate (set in stages).	With a medium setting of 2 to 3.	With a high setting: The lower the compartment temperature, the higher the energy consumption.
Temperature setting with a thermostat which is exact to the degree (digital display).	Cellar section 8 to 12°C	On appliances with winter setting, please make sure that the winter setting is switched off when the ambient temperature is warmer than 16 °C.
	Refrigerator section 4 to 5 °C	
	StayFresh zone approx. 0°C	
	Freezer section -18°C	
Use	Only open the door when necessary and for as short a time as possible.	Frequent opening of the door for long periods will cause a loss of coldness.
	Store food in an organised way.	If food is not stored in an organised way, searching for an item will mean the door is open for longer.
	Allow hot food and drinks to cool down before placing them in the appliance.	Placing hot food in the appliance will cause the compressor to run for a long time, as the appliance will have to work harder to lower the temperature.
	Store food covered or packaged.	The evaporation or condensation of liquids will cause a loss of coldness in the refrigerator.
	Place frozen food in the refrigerator to defrost.	
	Do not over-fill the sections to allow air to circulate.	
Defrosting	Defrost the freezer section when a layer of ice one centimetre thick has built up.	A layer of ice hinders the cold from reaching the frozen food, and causes an increase in energy consumption.

Before using for the first time

- Clean the inside of the appliance and the accessories with warm water and a little washing up liquid and then dry with a soft cloth.

Important:

To ensure correct functioning of the appliance, let it stand for between ½ and 1 hour after transporting it to its final location before connecting it to the mains.

Switching on



- Press the On-Off button.

The temperature display will start flashing and the alarm will sound. The appliance starts cooling. The interior light will come on when the door is opened.

Switching off the alarm



- Press the alarm button.

The alarm stops. The temperature display will continue to flash until the temperature range set has been reached.

Switching off

- Press the On-Off button.

The temperature display goes out and the cooling process is switched off. (If this does not happen, the safety lock is still engaged).

Safety lock

The safety lock can be engaged to prevent the temperature being changed or the appliance being switched off unintentionally.

To activate the safety lock



- Press and hold the locking button, until a beep is heard and the safety lock indicator light (⊕) in the temperature display lights up.

The appliance can now not be switched off and the temperature can not be adjusted until the lock has been de-activated.

De-activating the safety lock

- Press and hold the locking button, until the locking indicator light in the temperature display goes out.

The appliance can now be switched off at any time and the temperature adjusted.

The correct temperature and humidity

Wine keeps on maturing depending on the surrounding conditions. The length of time for which wine can be kept in good condition will depend on the temperature as well as on the air humidity.

Temperature

Wine can be stored at a temperature between 5°C and 18°C. The optimum temperature is around 10-12°C. Most white wines can be consumed at this temperature. It is best to take red wine out of the wine cellar about two hours before drinking. Open the wine to allow it to breathe and to develop its aroma. After two hours red wine will be at the correct temperature for drinking.

If wine is stored at a temperature above 22°C it will mature too quickly. Wine should not be stored below 5°C for a long period of time as it will not mature fully at this low temperature.

Fluctuations in temperature put wine under stress and interrupt the maturing process. It is therefore very important to maintain a constant temperature.

An ambient room temperature of 8-43°C will ensure that a constant temperature is maintained in the appliance. (This is a wider temperature range than the climate range quoted on the data plate).

Safety features

A thermostat prevents the temperature in the wine cellar falling below 2°C. If the external temperature should drop below this level, a heater element in the appliance switches on automatically to keep the temperature inside as constant as possible.

Setting the temperature

The temperature is set using the two buttons next to the temperature display.

Press the

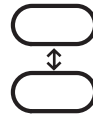

upper button: to increase the temperature (it gets warmer)

lower button: to reduce the temperature (it gets colder)

The temperature being set will flash in the display.

When pressing the buttons, the following information shows in the display:

- When first pressed, the **last temperature selected** flashes.
- Each subsequent press of the button adjusts the temperature shown in 1 °C steps.
- Keeping the button pressed in adjusts the temperature continually.

Approx. 5 seconds after letting go of the button, the **current** temperature inside the appliance is automatically shown.

The correct temperature and humidity

Temperature range

The temperature can be adjusted from 5°C to 22°C.

Temperature display

During normal operation, the temperature display on the control panel shows the temperature inside the appliance.

If the temperature in the appliance is not within the range that the appliance is able to display (i.e. 2-30°C), only bars will light up in the temperature display.

Depending on the ambient temperature and the setting, it can take the appliance up to 8 hours to reach the temperature required and for this temperature to then be shown as a constant temperature in the display.

The **temperature display will flash**, if

- a different temperature is being set,
- the temperature in the wine cellar is too high or too low.

Temperature display brightness

The appliance is supplied with the brightness of the temperature display set as low as possible. However, if the door is opened, a setting changed or if the alarm is sounding, the temperature display will appear much brighter for approx. 1 minute.

The level of brightness can be adjusted to be:

- **Brighter:** by pressing the alarm off button and, whilst holding it in,

pressing the upper button next to the temperature display.

- **Dimmer:** by pressing the alarm off button, and whilst holding it in, pressing the lower button next to the temperature display.

Humidity level

It is very important to store wine in an atmosphere with a high humidity level (60-70 %) so that the corks remain moist on the outside. A refrigerator with its low humidity level is therefore not the best place to store wine. Low humidity causes corks to dry out from the outside, and so they do not seal the bottles as tightly. Wine should be stored lying down to keep the corks moist from the inside too! Air entering the bottle will inevitably spoil the wine.

Ideal humidity levels can be maintained inside the appliance as long as the ambient room temperature is between 15°C and 35°C.

Useful tip: Before serving, stand the wine upright for at least two hours, or the entire day if possible, to allow any sediment to settle at the bottom of the bottle.

The correct temperature and humidity

Air filtering with the active charcoal filter and dynamic cooling

The active charcoal filter and the dynamic cooling system work together to ensure a good air flow is maintained throughout the cabinet and thus achieve optimum air quality.

The dynamic cooling system draws fresh air with a humidity level of 60-70% from outside the appliance, in through the active charcoal filter and distributes it evenly around the interior.

Filtering the incoming air through the active charcoal filter ensures that all the air entering the appliance is fresh and free from dust. Because the temperature is constant and evenly distributed throughout the unit you have the reassurance that all your wines are being kept in the same condition.

Replace the active charcoal filter with a new one once a year (see "Cleaning and care"). These are available from your dealer.

Wooden shelves

Any vibration or movement of the bottle can affect the wine by interrupting the natural respiration process and so impair the taste.

As far as possible, store bottles of the same type of wine beside each other on the same shelf. Removing a bottle of one type will then leave the other types undisturbed and will avoid the need to move different bottles around.

You can adjust the height of the wooden shelves to suit your individual requirements.

Descriptive labels

Use the labels supplied to identify your wine quickly and easily. Insert the labels into the wooden shelf fronts from above.

Additional labels can be purchased from your dealer or from the Miele Spare Parts Department.

Maximum capacity

The following data was obtained using standard Bordeaux wine bottles (0.75 l) and the number of shelves supplied with the appliance.

- KWL 4612 S: up to 169 bottles
- KWL 4812 S: up to 196 bottles

Alarm

Your appliance is fitted with a warning system which ensures that the temperature cannot rise or fall unnoticed and impair the wine.

Temperature alarm

The alarm will sound if the temperature in the appliance rises approx. 4°C above or falls approx. 4°C below the set temperature. The temperature display will flash at the same time.

The alarm will sound and the temperature display will flash:

- when you switch the appliance on for the first time.
- when you switch the appliance on if the temperature in the appliance is very different from the temperature set.
- when there has been a lengthy interruption to the power supply.

Door alarm

The alarm will sound if the door is left open for more than approx. 3 minutes.

Switching on the alarm system

The alarm system is always active. It does not have to be switched on manually.

Switching the alarm off early

Once the set temperature has been reached in the appliance, the alarm stops and the temperature display lights up constantly. However, if the noise disturbs you, you can switch the alarm off before this if you wish.



- Press the alarm off button.
The alarm will stop. The temperature display will continue to flash until the set temperature has been reached or the door has been shut again. The display then lights up constantly, and the alarm system is now fully active once more.

Condensate and frost can build up on the back wall of the appliance whilst it is in use. These are automatically removed and defrosted by the appliance.

The condensate is drained away via a channel and drain hole into an evaporation system at the back of the appliance.

Ensure that the condensate channel and drain hole are never blocked so that condensate can flow away without hindrance.

Cleaning and care

Never use cleaning agents containing abrasive substances such as sand, soda, acids or chemical solvents. "Non-abrasive" cleaning agents are also unsuitable as they can cause matt areas to appear.

Make sure that water cannot get into the electronic unit or into the lighting.

Do not let water get into the drainage channel and drain hole when cleaning.

Do not use steam cleaning apparatus to clean the appliance. Steam could reach the electrical components and cause a short circuit.

The data plate located inside the appliance must not be removed. It contains information which is required in the event of a Service call.

Before cleaning

- Switch the appliance off at the wall socket and remove the plug.
- Take out any removable parts, e.g. shelves, for cleaning.

Cleaning the outer casing, the interior and accessories

Use warm water with a little washing up liquid. Accessories and shelves should all be hand-washed only.

- Clean the condensate channel and drain hole frequently, so that condensate can drain away unhindered. Use a straw or similar to clear the drain if necessary.
- After cleaning, wipe the outer casing, the interior and accessories with a damp cloth and dry with a soft cloth. Leave the door open to air the appliance for a short while.

E-Cloth

- A microfibre "E-Cloth" is available from the Miele UK Spare Parts Department which is suitable for cleaning surfaces such as stainless steel, glass, plastic and chrome without the use of chemicals.

Ventilation gaps

- The ventilation gaps should be cleaned regularly with a brush or vacuum cleaner. A build-up of dust will increase the energy consumption of the appliance.

Door seal

Do not use any oils or grease on the door seal as these will cause the seal to deteriorate and become porous over time.

The door seal should be cleaned regularly with clean water and then wiped dry with a soft cloth.

Metal grille at the back of the appliance

The metal grille at the back of the appliance (heat exchanger) should be dusted at least once a year. A build-up of dust will increase the energy consumption of the appliance.

When cleaning the grille, make sure that the pipework and other components do not get broken or damaged in any way.

Active charcoal filter

Replace the active charcoal filter with a new one once a year. Active charcoal filters are available from your dealer or the Miele Spare Parts Dept.

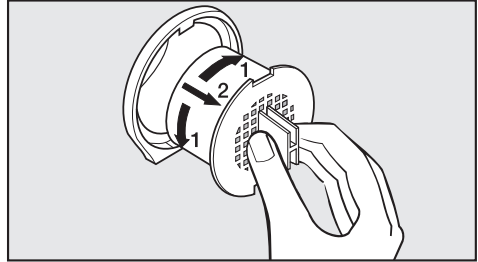

- Turn the filter 90° clockwise or anti-clockwise.
- Remove the filter.
- Insert a new filter with the handle in the vertical position.
- Turn the filter 90° clockwise or anti-clockwise until it clicks into position.

After cleaning

- Replace all shelves in the appliance.
- Insert the plug in the socket and switch the appliance back on.

Problem solving guide

Repairs to electrical appliances should only be carried out by a suitably qualified and competent person in accordance with local and national safety regulations. Repairs and other work by unqualified persons could be dangerous. The manufacturer cannot be held liable for unauthorised work.

Ensure current is not supplied to the appliance until after maintenance or repair work has been carried out.

Some minor problems can be corrected without contacting the Miele Service Department.

What to do if . . .

. . . the appliance does not get cool.

- Check whether the appliance has been switched on. The temperature display must be lit up.
- Check that the plug is correctly inserted in the socket and switched on.
- Check that the fuse is not defective and that the mains fuse has not blown. If it has, contact the Miele Service Department.

. . . the appliance is switching in too frequently and for too long.

- Check whether the ventilation gaps have been covered over or become too dusty.
- Check whether the metal grille (heat exchanger) at the back of the appliance has become too dusty.

- Check whether the appliance door is being opened frequently.
- Check that the door has been closed properly.

. . . the alarm sounds and the temperature display flashes.

- Has the appliance been switched on for the first time?

If not, then the temperature inside the appliance is higher or lower than the temperature that has been set. This could be due to:

- the appliance door being opened too often.
- a blocked ventilation gap.
- a lengthy interruption to the power supply.

Once the problem has been resolved the temperature display will light up constantly and the alarm will stop.

. . . a bar is lit up or flashing in the temperature display.

Only temperatures within the range the appliance can display will be shown. If the temperature is not within this range, a bar will be displayed instead.

. . . "F1" or "FU" appears in the temperature display.

There is a fault. Call the Service Department.

. . . you cannot switch the appliance off.

The safety lock has been activated.

. . . the interior light is not working.

- Was the door left open for too long?
The light switches itself off automatically after approx. 15 minutes.

If this is not the case, then the lamp is defective.

- Disconnect the appliance from the mains. Switch off at the wall and withdraw the plug from the socket, or disconnect the mains fuse or remove the screw-out fuse in countries where this is applicable.

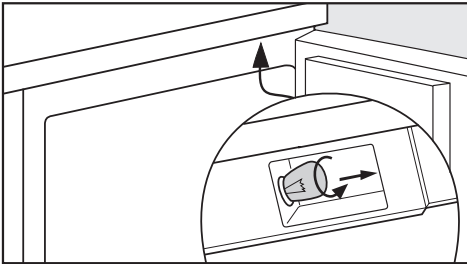

- Unscrew the lamp and replace it with a new one.

Lamp specification:
220 - 240 V, max. 15 W, E 14 fitting.

- Screw the new lamp into the connection.

If you still cannot remedy the fault having followed these suggestions, please contact the Miele Service Department.

To prevent unnecessary loss of temperature it is advisable not to open the door while waiting for the appliance to be serviced.

Noises

Normal noises	What causes them
Brrrrr...	Humming noise made by the motor (compressor). This noise can get louder for brief periods when the motor is switching on.
Blubb, blubb....	A gurgling noise can be heard when coolant is circulating through the pipes.
Click....	Clicking sounds are made when the thermostat switches the motor on and off.
Sssrrrrr....	On multi-zone and frost free appliances you can sometimes just hear the movement of air circulating inside the appliance.

Remember that the noise of the compressor and the coolant circulating in the system is unavoidable.

Noises that you can easily rectify	What causes them, and what can you do about them?
Rattling, vibrating	The appliance is uneven: Realign the appliance using a spirit level, by raising or lowering the screw feet underneath the appliance.
	The appliance is touching another appliance or piece of furniture: Move it away.
	Drawers, baskets or shelves are unstable or sticking: Check all removable items and refit them correctly.
	Are any bottles or containers unstable or knocking against each other? Separate them.
	The transport cable clips are hanging loose at the back of the appliance: Remove the clips.

In the event of a fault which you cannot correct yourself, or if the appliance is under guarantee, please contact:

– Your Miele Dealer

or

– The Miele Service Department (see back cover for address).

When contacting your Dealer or the Service Department, please quote the model and serial number of your appliance. This information is given on the data plate.

Please note that telephone calls may be monitored and recorded to improve our service.

Electrical connection

Electrical connection U.K.

All electrical work should be carried out by a suitably qualified and competent person in accordance with local and national safety regulations.

The appliance is supplied with a mains cable and moulded plug ready for connection to an a.c. single phase 220-240 V 50 Hz supply.

The voltage and connected load are given on the data plate. Please ensure that these match the household mains supply. The fuse rating is quoted on the plug.

Connection should be made via a suitable switched socket which is easily accessible. For extra safety it is advisable to install a residual current device (RCD) with a trip current of 30 mA (in accordance with DIN VDE 0664, VDE 0100, Section 739).

Do not connect the appliance to the mains electricity supply by an extension lead. Extension leads do not guarantee the required safety of the appliance (e.g. danger of overheating).

The appliance must not be connected to an inverter and must not be used with a plug adapter as these can cause damage to the appliance's electronic unit.

Non-rewireable plugs (BS 1363)

The fuse cover must be re-fitted when changing the fuse, and if the fuse cover is lost, the plug must not be used until a suitable replacement is obtained. The colour of the correct replacement cover is that of the coloured insert in the base of the plug, or the colour that is embossed in words in the base of the plug (as applicable to the design of the plug fitted).

Replacement fuses should be ASTA approved to BS 1362 and have the correct rating. Replacement fuses and fuse covers may be purchased from your local electrical supplier.

WARNING
THIS APPLIANCE MUST BE
EARTHED

Do not place any appliance which gives off heat, such as a toaster or microwave oven, on top of this appliance, as this would increase the appliance's energy consumption.

Location

The appliance should be installed in a dry, well-ventilated room.

The room temperature should not go above or below the climate range for which the appliance is designed. The higher the ambient temperature of the room, the more energy the appliance requires to operate.

It should not be installed where it is exposed to direct sunlight or directly adjacent to a heat-producing appliance such as an oven or a radiator.

Climate range

The climate range of the appliance is stated on the data plate inside the appliance.

Climate range	Ambient room temperature
SN	+10°C to +32°C
N	+16°C to +32°C
ST	+18°C to +38°C
T	+18°C to +43°C

This appliance can operate in a wider room temperature range than indicated by the climate range. A constant temperature will be maintained in the appliance at an ambient room temperature of 8 to 43 °C. It is important that the room temperature should be kept within this range.

Ventilation

The appliance can be placed directly against a wall. To ensure sufficient ventilation, the ventilation gaps must not be covered over. The air inlet and outlet must not be covered or blocked in any way. They should be dusted on a regular basis.

Installation

- Remove any cable clips from the back of the appliance.
- Check that all parts at the back of the appliance are unhindered. Remove any hindrance.
- Carefully push the appliance into position.

Aligning the appliance

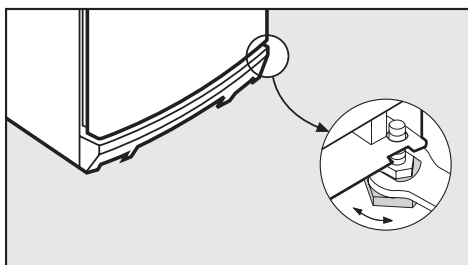

- To align the appliance adjust the feet using the spanner supplied.

Changing the door hinging

The appliance is supplied right hand hinged. If left hand door hinging is required, follow the instructions below.

Removing the door handle:

First the side section of the handle must be removed:

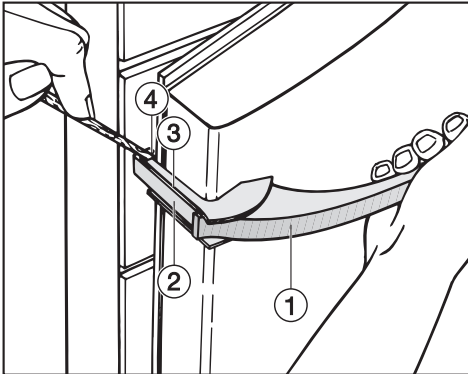

- Pull door handle ① towards you. Side section ② slides back, creating a gap ④ between side section ② and mounting plate ③.
- Place a suitable object (e.g. a spoon handle) in gap ④, and slowly lever the handle towards the door.

Be careful not to let the "spoon handle" slip, causing damage to the appliance.

The side section ② can now be removed.

- Pull side section ② out of the guides on the mounting plate.
- Loosen the 4 screws (Torx 15) in the mounting plate, and remove the handle.

- Remove the cover caps from the opposite side, and fit them into the empty holes.

Changing over the door:

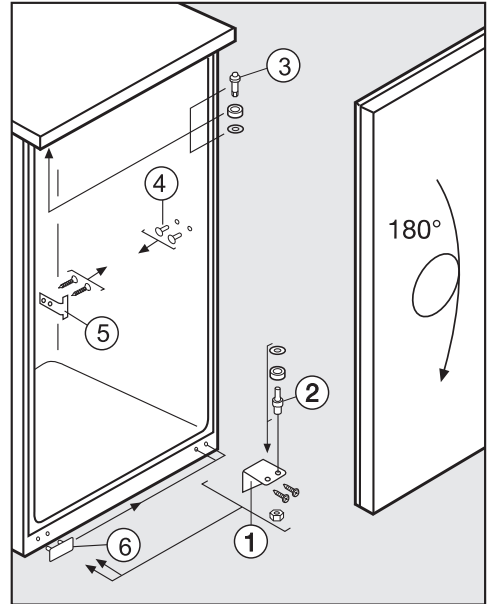

- Close the appliance door, unscrew hinge bracket ①, and take the door off.
- Take hinge pin ② out of the hinge bracket, then refit it in the second hole of the hinge bracket. (Use the spanner supplied to unscrew and refit the hinge pin).
- Use the spanner supplied to unscrew upper hinge pin ③, and refit it on the other side.
- Remove stoppers ④, and unscrew bracket ⑤. Refit the bracket and stoppers on the other side of the door.

Changing the door hinging

- Rotate the door 180°.
- Remove cover ⑥ and use it to cover the now empty holes on the opposite side.
- Hang the door on the upper hinge pin and close the door.
- Fit the hinge bracket in the lower door bearing. Then screw it securely to the appliance plinth.

Use the long slots in the hinge bracket to align the door.

Refitting the handle:

Please make sure you follow the instructions below carefully when you refit the handle. The door seal will be damaged if the handle is fitted incorrectly.

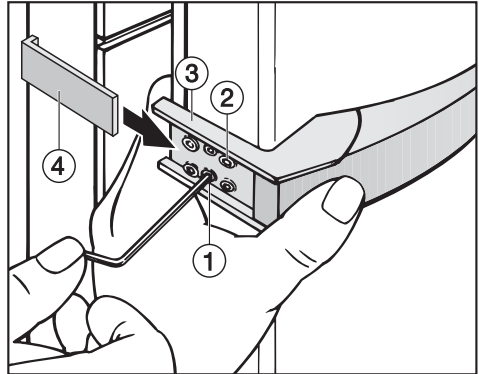

- Loosely attach the handle to the opposite side of the door with the two front screws ②.

Mounting plate ③ must be positioned on the side of the door so that when the door is **closed** it is flush with the side of the appliance.

If this is not the case,

- Tighten both grub screws ① with the allen key provided until mounting plate ③ lines up correctly.
- Then tighten all 4 fixing screws ②.
- Slide the side section of the handle ④ into the guides on the mounting plate until it clicks into place.

Changing the door hinging

It is important to check that the side section of the handle ④ does not come into contact with the door seal when opening the door, as this would damage the door seal permanently.

If, after you have refitted the handle, you find that the side section does touch the door seal when the door is opened:

Realign mounting plate ③ with grub screws ① until the mounting plate and the side section of the handle ④ are at the correct angle and the side section does not touch the seal when the door is opened.

Miele

United Kingdom:

Miele Co. Ltd.
Fairacres, Marcham Road
Abingdon, Oxon, OX14 1TW
tel. Abingdon (01235) 554455
Service Office: (01235) 554466
fax (01235) 554477
Internet: www.miele.co.uk

Ireland:

Miele Ireland Ltd.
Broomhill Road, Tallaght, Dublin 24
Tel: (01) 46 10 710, Fax: (01) 46 10 797
Email: info@miele.ie
Internet: <http://www.miele.ie>

Australia:

Miele Australia Pty. Ltd.
A.C.N. 005635398
1 Gilbert Park Drive
Knoxfield, VIC 3180
Telephone: (03) 9764 7100
Fax: (03) 9764 7129
Internet: www.miele.com.au

Distributor New Zealand:

Steelfort Engineering Company. Ltd.
500 Rangitikei Street
Palmerston North, Priv. Bag 11045, NZ
Telephone: (06) 350 1350
Fax: (06) 356 1507

South Africa:

Miele (Pty) Ltd
63 Peter Place
Bryanston 2194
P.O. Box 69434
Bryanston 2021
Tel.: (011) 548 1900
Telefax (011) 548 1935
Internet: www.miele.co.za
E-mail: info@miele.co.za

Singapore:

Miele Southeast Asia
Miele Pte. Ltd.
163 Penang Road
04 - 02/03 Winsland House II
Singapore 238463
Tel : +65-67351191
Fax: +65-67351161
Email: infosea@miele.com.sg

Hong Kong:

Miele (Hong Kong) Limited
AIA Plaza, 24th Floor
18 Hysan Avenue
Causeway Bay
Hong Kong
Tel.: (852) 2610 1331
Fax: (852) 2610 1013
E-mail: mielehk@miele.com.hk